

# 221 **BBH** 460 **4T**

GASOLINE TILLER (4-STROKE)



USER MANUAL

# INTRODUCTION

## SAFETY MESSAGES

Your safety and the safety of others are very important. And using this tiller safely is an important responsibility.

To help you make informed decisions about safety, we have provided operating procedures and other information on labels and in this manual. This information alerts you to potential hazards that could hurt you or others.

Of course, it is not practical or possible to warn you about all the hazards associated with operating or maintaining a tiller. You must use your own good judgment.

You will find important safety information in a variety of forms, including:

- **Safety Labels**
- **Safety Messages** -- preceded by a safety alert symbol  and one of three signal words: DANGER, WARNING, or CAUTION.

These signal words mean:

### DANGER

You WILL be KILLED or SERIOUSLY HURT if you don't follow instructions.

### WARNING

You CAN be KILLED or SERIOUSLY HURT if you don't follow instructions.

### CAUTION

You CAN be HURT if you don't follow instructions.

- **Safety Headings** --such as *IMPORTANT SAFETY INFORMATION*.
- **Safety Section** --such as *TILLER SAFETY*.
- **Instructions** --how to use this tiller correctly and safely.

This entire book is filled with important safety information--please read it carefully.

# CONTENTS

<b>TILLER SAFETY</b> .....	<b>1</b>
IMPORTANT SAFETY INFORMATION.....	2
SAFETY LABEL LOCATIONS.....	3
<b>CONTROLS</b> .....	<b>4</b>
COMPONENT & CONTROL LOCATIONS.....	4
CONTROLS .....	5
<b>SETTING UP YOUR NEW TILLER</b> .....	<b>7</b>
HANDLE BAR BRACKET ASSEMBLY .....	7
REVERSE CABLE ASSEMBLY.....	7
CLUTCH CABLE ASSEMBLY.....	7
WHEEL ASSEMBLY.....	8
BUMPER ASSEMBLY.....	8
<b>BEFORE OPERATION</b> .....	<b>9</b>
ARE YOU READY TO GET STARTED.....	9
IS YOUR TILLER READY TO GO.....	9
<b>OPERATION</b> .....	<b>10</b>
SAFE OPERATING PRECAUTIONS.....	10
STARTING THE ENGINE.....	10
OPERATING THE CONTROLS FOR TILLING.....	13
HANDLING TIPS.....	14
STOPPING THE ENGINE.....	15
<b>SERVICING YOUR TILLER</b> .....	<b>16</b>
THE IMPORTANCE OF MAINTENANCE.....	16
MAINTENANCE SAFETY.....	17
MAINTENANCE SCHEDULE.....	18
REFUELING.....	19
FUEL RECOMMENDATIONS.....	20
ENGINE OIL LEVEL CHECK.....	20
ENGINE OIL CHANGE.....	21
ENGINE OIL RECOMMENDATIONS.....	22
TRANSMISSION OIL RECOMMENDATIONS.....	22
AIR FILTER INSPECTION.....	23
AIR FILTER CLEANING.....	23
CLUTCH CABLE ADJUSTMENT.....	24
REVERSE CABLE ADJUSTMENT.....	24
SPARK PLUG SERVICE.....	24
DRIVE BELT CHANGE.....	26
TINE REPLACEMENT.....	29
SPARK ARRESTER SERVICE (optional equipment).....	29
TIRE PRESSURE CHECK.....	30
<b>STORAGE</b> .....	<b>31</b>
STORAGE PREPARATION.....	31
STORAGE PRECAUTIONS.....	35
<b>TAKING CARE OF UNEXPECTED PROBLEMS</b> .....	<b>36</b>

# TILLER SAFETY

---

## IMPORTANT SAFETY INFORMATION

Tillers are designed to cultivate earth outdoors. Other uses can result in injury to the operator or damage to the tiller and other property.

Most accidents can be prevented if you follow all instructions in this manual and on the tiller. The most common hazards are discussed below, along with the best way to protect yourself and others.

### Operator Responsibility

- Know how to stop the tiller quickly in case of emergency.
- Understand the use of all tiller controls.
- Be very cautious when operating the tiller in REVERSE, especially if attachments are being used.
- Keep a firm hold on the handlebars. They may tend to lift during clutch engagement.
- Be sure the drag bar is in place and properly adjusted.
- Be sure that anyone who operates the tiller receives proper instruction. Do not let children operate the tiller. Keep children and pets away from the area of operation.

### Avoid Rotating Tines

Rotating tines can cause serious cuts and even amputate body parts. Keep away from the tine area whenever the engine is running. If you need to work around the tines to clear an object accumulation or for any other reason, always shut off the engine. Disconnect the spark plug cap, and wear heavy gloves when you need to clean the tine area or handle the tines.

# TILLER SAFETY

---

## Clear Tilling Area

A tine can throw rocks and other objects with enough force to cause serious injury. Before tilling, carefully inspect the area and remove all stones, sticks, bones, nails, pieces of wire, and other loose objects. Be aware if children are in the area, stop the tiller. Never operate the tines over gravel.

## Keep Shields in Place

Guards and shields are designed to protect you from being hit by thrown objects and to keep you from touching hot engine parts and moving components. For your safety and the safety of others, keep all shields in place when the engine is running.

## Wear Protective Clothing

Wearing protective clothing will reduce your risk of injury. Long pants and eye protection reduce the risk of injuries from thrown objects. Sturdy shoes with aggressive soles provide better traction.

## Turn Engine Off When Not Operating the Tiller

If you need to leave the tiller for any reason, even just to inspect the area ahead, always turn the engine off.

## Slope Operation

- When tilling on slopes, keep the fuel tank less than half full to minimize fuel spillage.
- Till across the slope (at equally spaced intervals) rather than up and down it.
- Be very careful when changing the direction of the tiller on a slope.
- Do not use the tiller on a slope of more than 10. Before starting the engine, check that the tiller is not damaged and is in good condition. For your safety and the safety of others, exercise extreme care when using the tiller on a slope.

# TILLER SAFETY

## SAFETY LABEL LOCATIONS

These labels warn you of potential hazards that can cause serious injury. Read them carefully. If a label comes off or becomes hard to read, contact your dealer for a replacement.

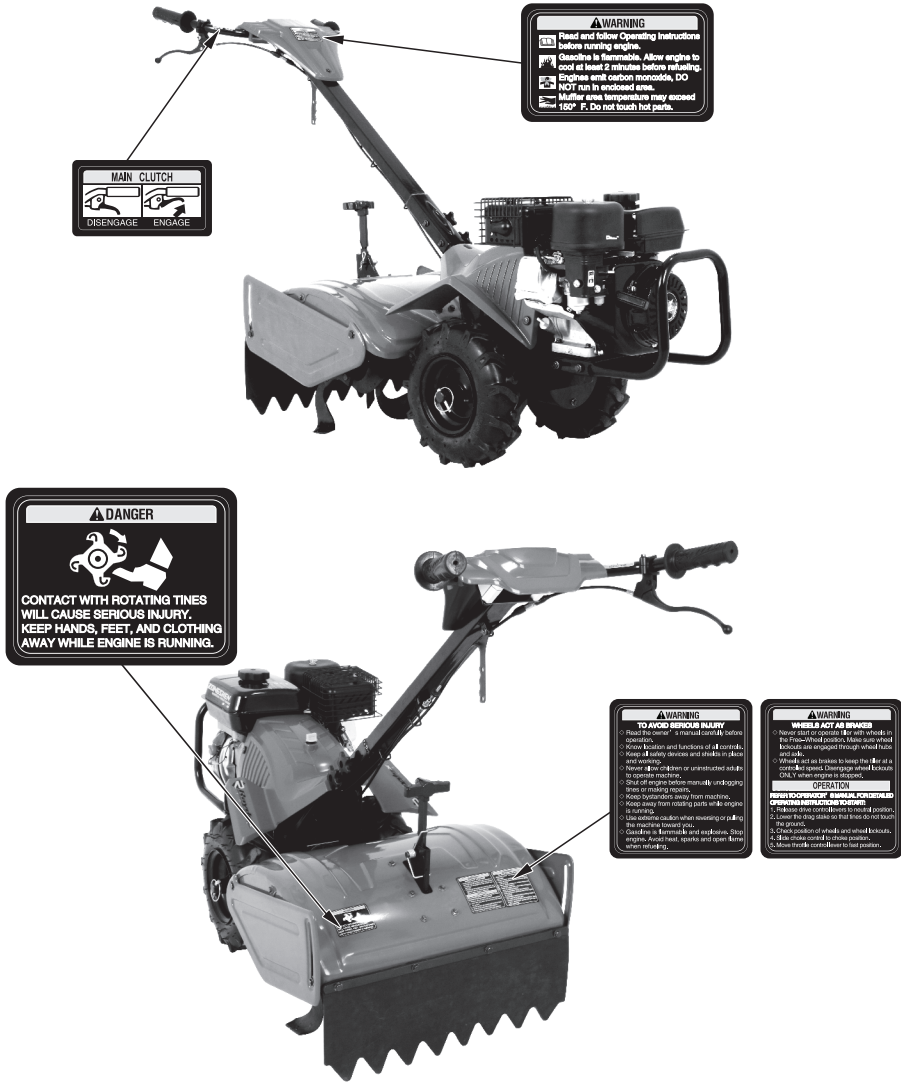

# CONTROLS

## COMPONENT & CONTROL LOCATIONS

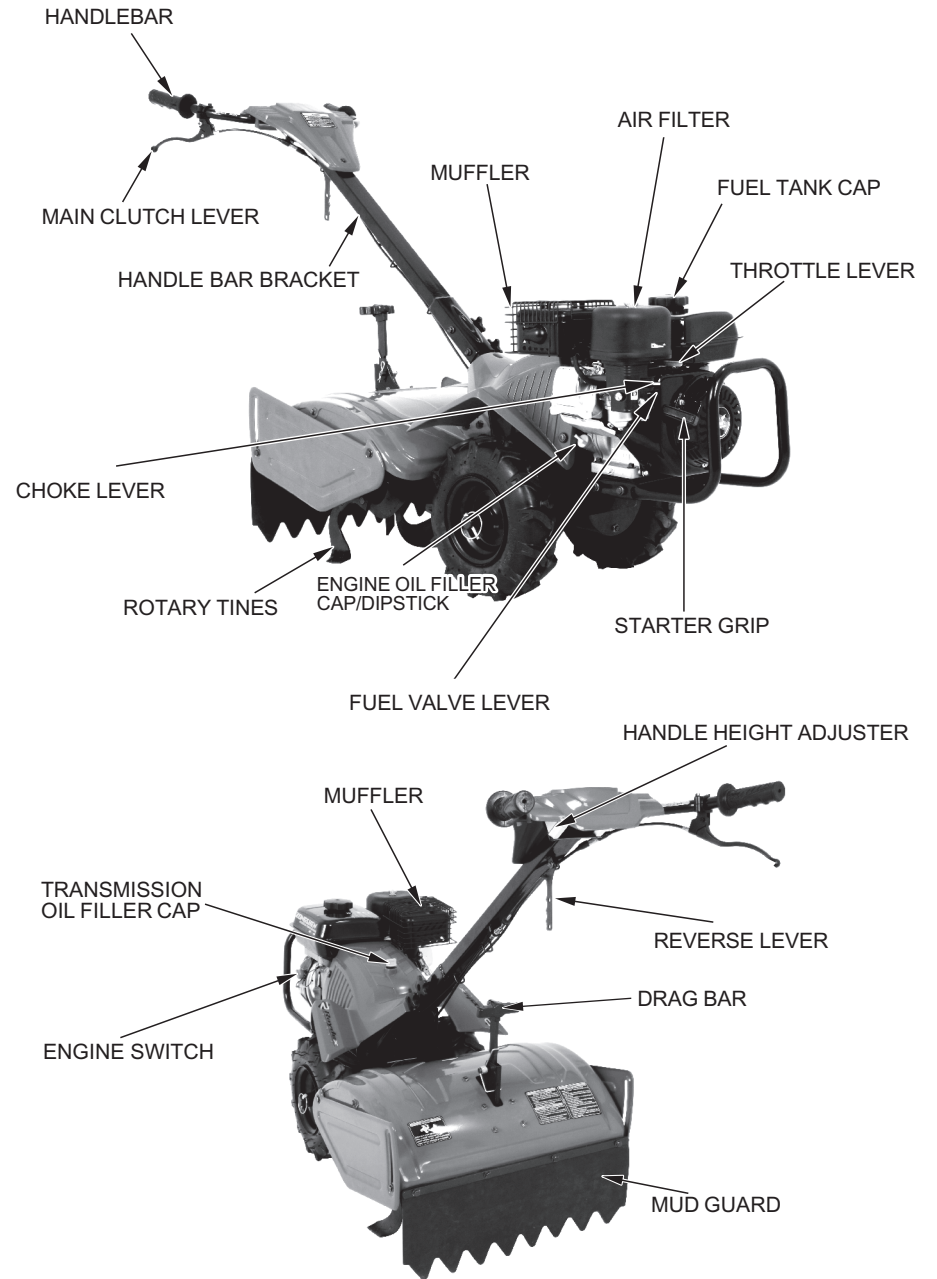

# CONTROLS

## Fuel Valve

The fuel valve opens and closes the connection between the fuel tank and the carburetor.

The fuel valve lever must be in the ON position for the engine to run.

After stopping the engine, turn the fuel valve lever to the OFF position.

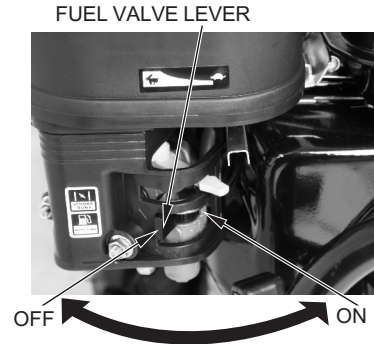

## Choke Lever

The choke lever opens and closes the choke valve in the carburetor.

The CLOSED position enriches the fuel mixture for starting a cold engine.

The OPEN position provides the correct fuel mixture for operation after starting and for restarting a warm engine.

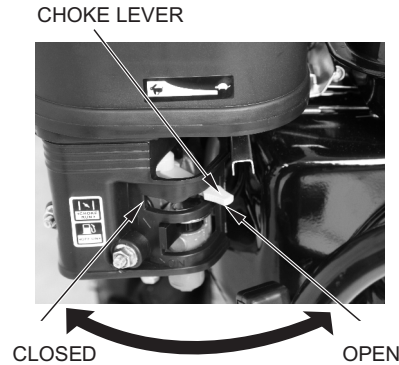

## Engine Switch

The engine switch controls the ignition system.

OFF--Stops the engine.  
ON--Running position.

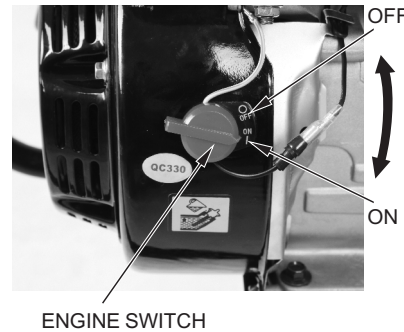

## Main Clutch Lever

The main clutch lever engages and disengages the transmission that drives the tines.

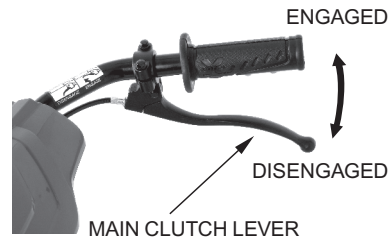

# CONTROLS

## Reverse Lever

The transmission offers a choice of one forward speed, neutral, and one reverse speed. Reverse lever engages and disengages the transmission backward.

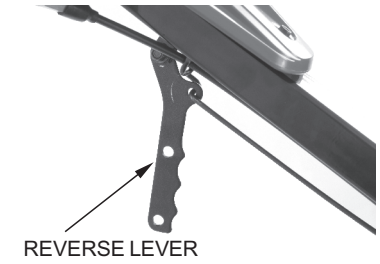

## Drag Bar

The drag bar controls tilling depth and should always be used when tilling. It enables you to compensate for the hardness of the soil. Ideal drag bar height will depend on the type of soil being tilled and soil conditions at the time of tilling. In general, the drag bar should be adjusted so that the tiller is tilted slightly backward.

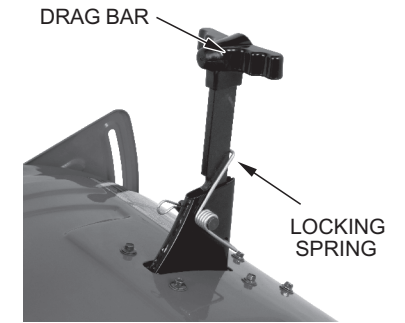

## Handlebar Height Adjuster

Handlebar height can be adjusted to match operator height.

For normal tilling, the most comfortable operator position is with the handlebars at waist height.



## Starter Grip

Pulling the starter grip operates the recoil starter to crank the engine.

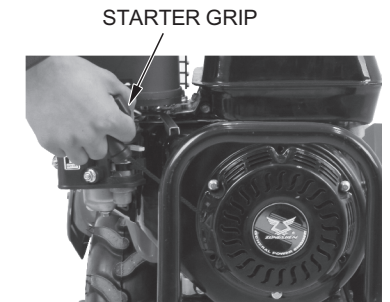

# SETTING UP YOUR NEW TILLER

## ASSEMBLY INSTRUCTION

### HANDLE BAR BRACKET ASSEMBLE

1. Carefully remove the tiller from package.
2. Fix handle bar bracket as shown and tighten bolts and locking nuts.

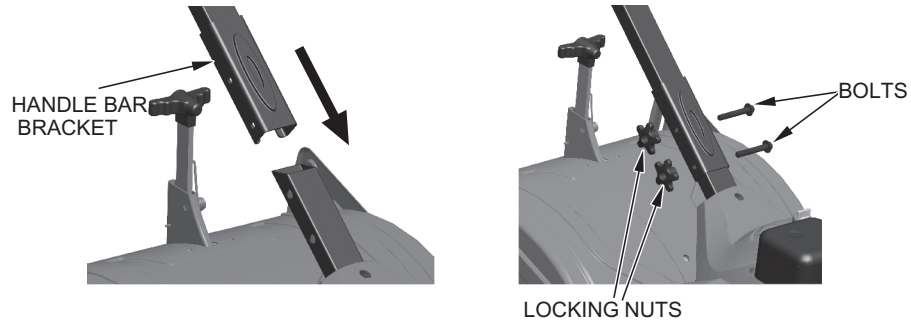

### REVERSE CABLE ASSEMBLY

1. Go through the fixing holes.
2. Fix the cable by the locking nuts.
3. Lock the reverse lever to handle bar bracket.

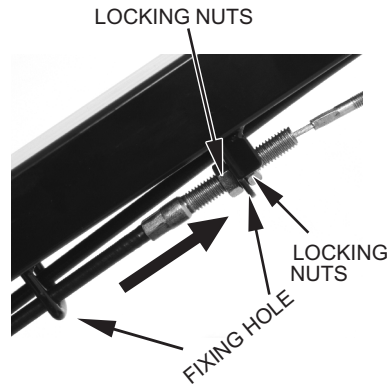

### CLUTCH CABLE ASSEMBLE

1. Go through the fixing holes.
2. Fix clutch cable head into clutch lever. Put the cable right the way.

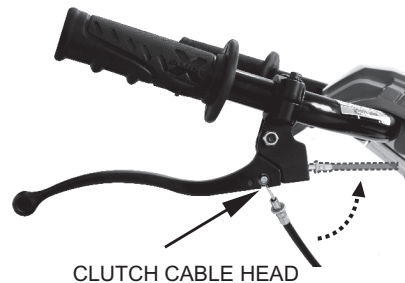

# SETTING UP YOUR NEW TILLER

## ASSEMBLY INSTRUCTION

### WHEEL ASSEMBLY

1. Install the wheels, two positions for different purposes.

Free wheel position for transportation, Tilling position for working.

When the tiller is ready to go, you should change the wheels from free wheel position to tilling position by adjusting the locking hole.

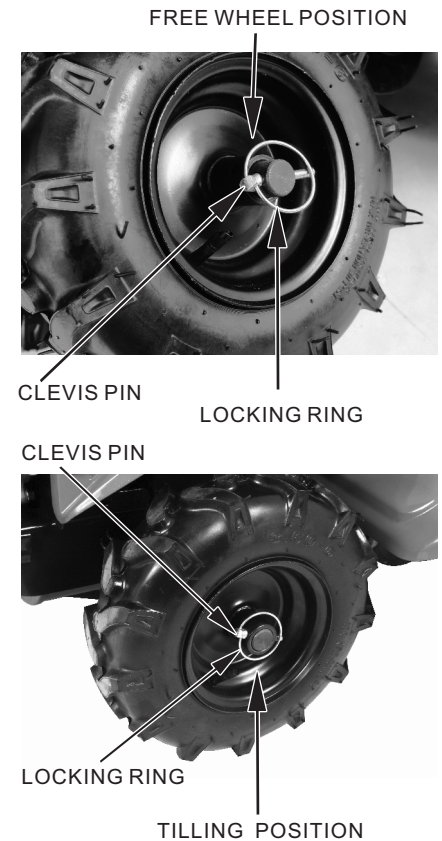

### BUMPER ASSEMBLY

1. Install the bumper by the locking screws.

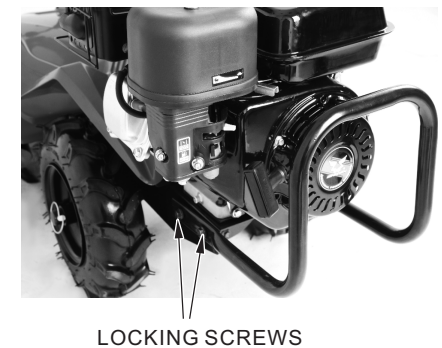

# BEFORE OPERATION

## ARE YOU READY TO GET STARTED?

Your safety is your responsibility. A little time spent in preparation will significantly reduce your risk of injury. Read and understand this manual. Know what the controls do and how to operate them. Know how to quickly shut off the tiller in case of an emergency.

You must be alert and in good physical condition to operate the tiller. Do not operate the tiller if you are tired, ill, or under the influence of alcohol, medication, or any substance that might impair your vision, dexterity, or judgment.

Wearing protective clothing will reduce your risk of injury. Do not wear loose clothing, jewelry, short pants, sandals, or go barefoot. Secure hair so it is above shoulder level. Wear gloves, a long-sleeved shirt, and long pants made of heavy material. Clothing should fit closely but allow freedom of movement, and should have no strings, straps, etc. that could catch on brush or the tiller. Keep clothing fastened. Wear sturdy work boots with good toe protection and nonslip soles.

## IS YOUR TILLER READY TO GO?

For your safety, and to maximize the service life of your equipment, it is very important to take a few moments before you operate the tiller to check its condition. Be sure to take care of any problem you find, or have your servicing dealer correct it, before you operate the tiller.

### WARNING

Improperly maintaining this tiller, or failing to correct a problem before operation, could cause a malfunction in which you could be seriously injured.

Always perform a pre-operation inspection before each operation, and correct any problem.

# OPERATION

## SAFE OPERATING PRECAUTIONS

Before operating the tiller for the first time, please review both the *TILLER SAFETY* chapter and the chapter titled *BEFORE OPERATION*.

For your safety, avoid starting or operating the tiller in an enclosed area such as a garage. Your tiller's exhaust contains poisonous carbon monoxide gas that can collect rapidly in an enclosed area and cause illness or death.

### WARNING

Carbon monoxide gas is toxic. Breathing it can cause unconsciousness and even kill you.

Avoid any enclosed areas or activities that expose you to carbon monoxide.

## STARTING THE ENGINE

### WARNING

Tines are sharp and spin fast.

Spinning tines can cut you severely and can amputate body parts.

- Wear protective footwear.
- Keep your hands and feet away from the tines while the engine is running.
- Stop the engine before performing any adjustment, inspection, or maintenance.

## OPERATION

1. Turn the fuel valve lever to the ON position. Check that the fuel drain screw is tightened securely.

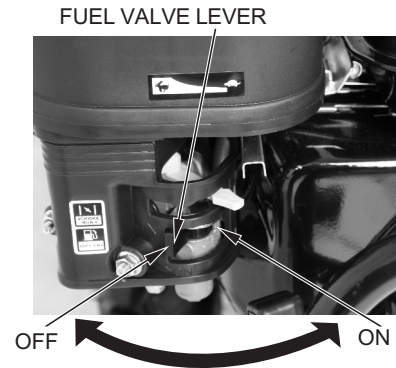

2. Move the choke lever to the CLOSED position to start a cold engine.

Leave the choke lever in the OPEN position to restart a warm engine.

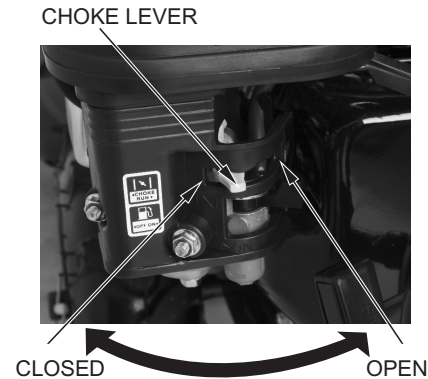

3. Turn the engine switch to the ON position.

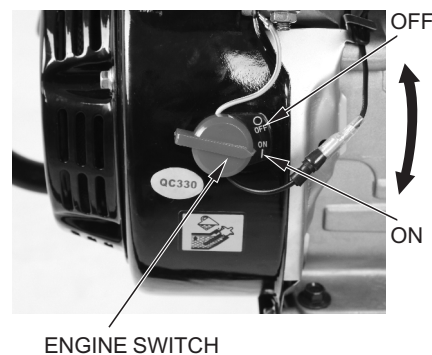

## OPERATION

4. Move the throttle lever away from the SLOW position, about 1/3 of the way toward the FAST position.

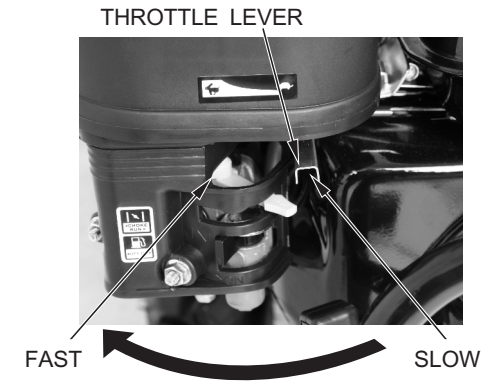

5. Pull the starter grip lightly until you feel resistance, then pull briskly in the direction of the arrow as shown.

### NOTICE

*Do not allow the starter grip to snap back against the engine. Return it gently to prevent damage to the starter.*



6. If the choke lever was moved to the CLOSED position to start the engine, gradually move it to the OPEN position as the engine warms up.

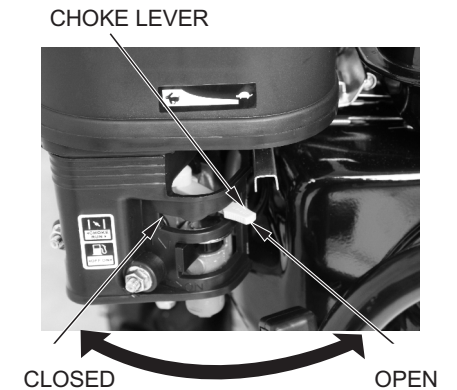

## OPERATING THE CONTROLS FOR TILLING

If the tines dig in but the machine will not move forward, move the handlebars from side-to-side.

### Handlebar Height Adjustment

Stop the engine before adjusting the handlebar height.

Loosen the height adjusting bolts, adjust the handlebar height and tighten the bolts. For normal tilling, the most comfortable operator position is with the handlebars at waist height.

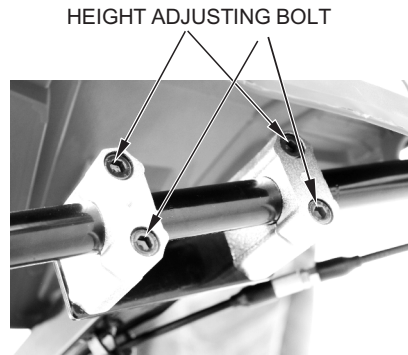

### Clutch

When the main clutch lever is squeezed, the clutch is engaged, and power is transmitted to the transmission.

When the lever is released, the clutch is disengaged, and power is not transmitted.

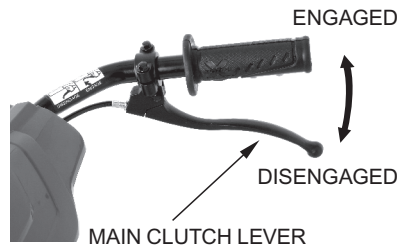

### Reverse Lever Operation

Use the reverse lever only when it is necessary to move the tiller away from an obstacle.

1. Check the area behind you and make sure it is clear of any obstacles.
2. Move the throttle to the SLOW position.
3. Make sure the main clutch lever is released.
4. Raise the handlebar slightly and engage the reverse lever.  
Carefully walk the tiller backwards.
5. Release the reverse lever, lower the handlebar when done.

## Tilling Depth Adjustment

The drag bar is used to control the tilling depth, which can be adjusted by holding the drag bar backward to release it and sliding the drag bar up and down as necessary.

During operation, if the machine jerks forward while tilling, press down on the handlebars. This will cause the drag bar to dig more deeply into the soil.

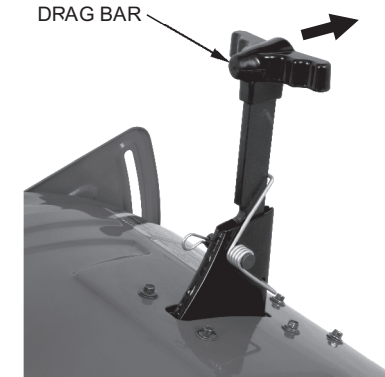

## HANDLING TIPS

- Adjust the handlebar height to a comfortable position (waist height for normal tilling).
- The drag bar should always be used when tilling. It enables you to compensate for the hardness of the soil. The ideal height of the drag bar will depend on the type of soil being tilled and soil conditions at the time of tilling. In general, however, the drag bar should be adjusted so that the tiller is tilted slightly backward.
- If the machine jerks forward while tilling, press down on the handlebars. This will cause the drag bar to dig more deeply into the soil.
- If tines dig in but the machine will not move forward, move the handlebars from side to side.
- Stop the tines before crossing gravel drives, walks, or roads. Stay alert for hidden hazards or traffic.
- Stop the engine immediately if the tiller vibrates abnormally. Check the tiller for damage or loose parts, and repair or replace them before using the tiller again. Vibration is usually a sign of trouble.

## OPERATION

### STOPPING THE ENGINE

To stop the engine in an emergency, simply turn the engine switch to the OFF position. Under normal conditions, use the following procedure.

1. Release the main clutch lever to the DISENGAGED position.

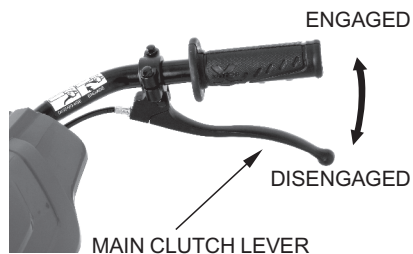

2. Turn the engine switch to the OFF position.

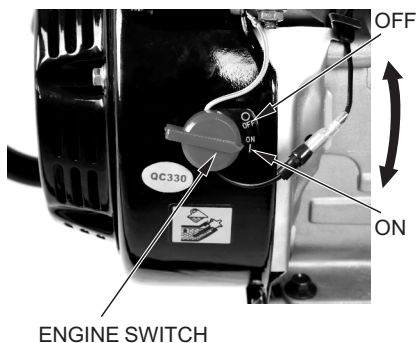

3. Turn the fuel valve lever to the OFF position.

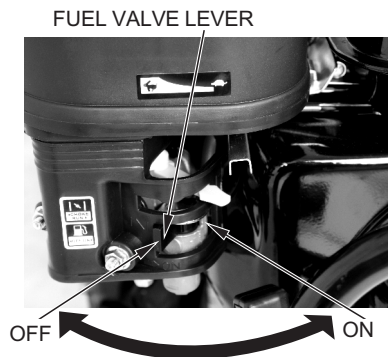

## SERVICING YOUR TILLER

### THE IMPORTANCE OF MAINTENANCE

Good maintenance is essential for safe, economical, and trouble-free operation. It will also help reduce air pollution.

To help you properly care for your tiller, the following pages include a maintenance schedule, routine inspection procedures, and simple maintenance procedures using basic hand tools. Other service tasks that are more difficult or require special tools are best handled by professionals and are normally performed by a qualified mechanic.

The maintenance schedule applies to normal operating conditions. If you operate your tiller under unusual conditions, such as sustained high-load or high-temperature operation or use in dusty conditions consult your servicing dealer for recommendations applicable to your individual needs and use.

### **⚠ WARNING**

Improper maintenance, or failure to correct a problem before operation, can cause a malfunction in which you can be seriously hurt or killed.

Always follow the inspection and maintenance recommendations and schedules in this owner's manual.

Remember that your servicing dealer knows your tiller best and is fully equipped to maintain and repair it.

To ensure the best quality and reliability, contact your dealer for parts.

**Maintenance, replacement, or repair of the emission control devices and systems may be performed by any engine repair establishment or individual.**

## MAINTENANCE SAFETY

Some of the most important safety precautions follow. However, we cannot warn you of every conceivable hazard that can arise in performing maintenance. Only you can decide whether or not you should perform a given task.

### **⚠ WARNING**

Failure to properly follow maintenance instructions and precautions can cause you to be seriously hurt or killed.

Always follow the procedures and precautions in the owner's manual.

## Safety precautions

- Make sure the engine is off before you begin any maintenance or repairs. This will eliminate several potential hazards:

### **Carbon monoxide poisoning from engine exhaust.**

Be sure there is adequate ventilation whenever you operate the engine.

### **Burns from hot parts.**

Let the engine and exhaust system cool before touching.

### **Injury from moving parts.**

Do not run the engine unless instructed to do so.

- Read the instructions before you begin, and make sure you have the tools and skills required.
- To reduce the possibility of fire or explosion, be careful when working around gasoline. Use only a non-flammable solvent, not gasoline, to clean parts. Keep cigarettes, sparks, and flames away from all fuel-related parts.
- Disconnect the spark plug cap and wear heavy gloves when working near the belts or tine blades.

## MAINTENANCE SCHEDULE

ITEM	REGULAR SERVICE PERIOD(2) Perform at every indicated month or operating hour interval, whichever comes first.	Each use	First month	Every 3 months	Every 6 months	Every year
			or 20 hrs.	or 50 hrs.	or 100 hrs.	or 300 hrs.
Engine oil	Check level	○				
	Change		○		○	
Transmission oil	Check level	○				
	Air filter	○				
	Clean			○ (1)		
	Replace					○
Clutch cable	Adjust		○		○	
Belt tension	Adjust		○ (3)		○ (3)	
Spark plug	Check-adjust				○	
	Replace					○
Sediment cup	Clean				○	
Spark arrester (applicable types)	Clean				○	
Reverse cable	Adjust		○			○
Idle speed	Check-adjust					○
Valve clearance	Check-adjust					○
Combustion chamber	Clean		After every 1000 hrs.			
Fuel tank & filter	Clean				○	
All fasteners (for tightness)	Check-tighten		Initial 10 hrs.			
Fuel tube	Check		Every 2 years (Replace if necessary)			

(1) Service more frequently when used in dusty areas.

(2) For commercial use, log hours of operation to determine proper maintenance intervals.

(3) Replace the belt if it is cracked or shows abnormal wear.

### REFUELING

With the engine stopped, remove the fuel tank cap and check the fuel level. Refill the tank if the fuel level is low. Do not fill above the fuel level mark.

#### **⚠ WARNING**

Gasoline is highly flammable and explosive.

You can be burned or seriously injured when handling fuel.

- Stop the engine and keep heat, sparks, and flame away.
- Refuel only outdoors.
- Wipe up spills immediately.

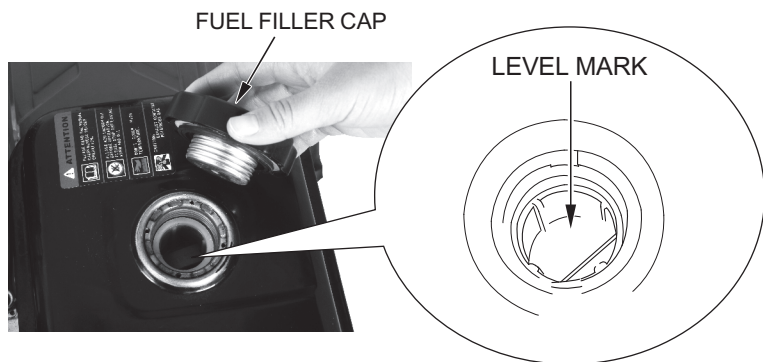

Refuel in a well-ventilated area before starting the engine. If the engine has been running, allow it to cool. Refuel carefully to avoid spilling fuel. Do not fill the fuel tank above the fuel level mark. After refueling, tighten the fuel tank cap securely.

Never refuel the engine inside a building where gasoline fumes may reach flames or sparks. Keep gasoline away from appliance pilot lights, barbecues, electric appliances, power tools, etc.

Spilled fuel is not only a fire hazard, it causes environmental damage. Wipe up spills immediately.

#### **NOTICE**

*Fuel can damage paint and plastic. Be careful not to spill fuel when filling your fuel tank.*

### FUEL RECOMMENDATIONS

This engine is certified to operate on unleaded gasoline with a pump octane rating of 86 or higher.

You may use regular unleaded gasoline containing no more than 10% ethanol (E10) or 5% methanol by volume. In addition, methanol must contain cosolvents and corrosion inhibitors.

Use of fuels with content of ethanol or methanol greater than shown above may cause starting and/or performance problems. It may also damage metal, rubber, and plastic parts of the fuel system.

Engine damage or performance problems that result from using a fuel with percentages of ethanol or methanol greater than shown above are not covered under warranty.

Never use stale or contaminated gasoline or an oil/gasoline mixture. Avoid getting dirt or water in the fuel tank.

If your equipment will be used on an infrequent or intermittent basis, please refer to the fuel section of the STORAGE chapter for additional information regarding fuel deterioration.

### ENGINE OIL LEVEL CHECK

Check the engine oil level with the tiller on a level surface and the engine stopped.

1. Remove the engine oil filler cap/dipstick and wipe it clean.
2. Insert and remove the engine oil filler cap/dipstick without screwing it into the oil filler neck. Check the oil level shown on the engine oil filler cap/dipstick.
3. If the oil level is low, fill with the recommended oil to the top of the oil filler neck.

- Screw in the engine oil filler cap/dipstick securely.

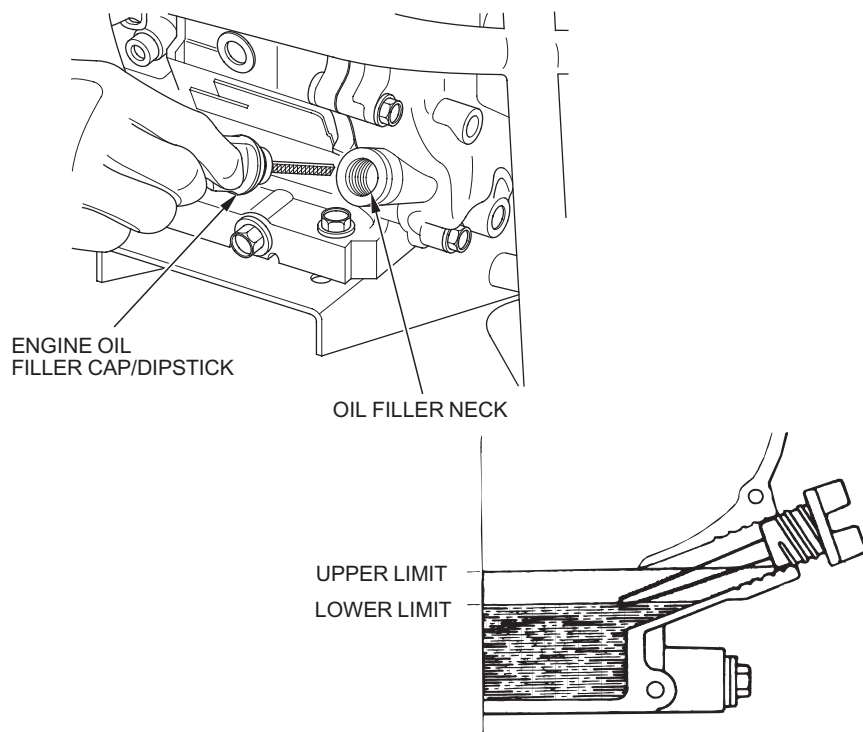

### ENGINE OIL CHANGE

Drain the oil while the engine is warm to assure rapid and complete draining.

- Place a suitable container below the engine to catch the used oil, and then remove the engine oil filler cap/dipstick, drain plug, and sealing washer.
- Allow the used oil to drain completely, and then reinstall the drain plug and sealing washer. Tighten the plug securely.

#### NOTICE

*Improper disposal of engine oil can be harmful to the environment. If you change your own oil, please dispose of the used oil properly.*

- With the tiller in a level position, fill with the recommended oil to the outer edge of the oil filter hole.

#### NOTICE

*Running the engine with a low oil level is misuse and can cause engine damage.*

- Screw in the engine oil filler cap/dipstick securely.

### ENGINE OIL RECOMMENDATIONS

Oil is a major factor affecting performance and service life. Use a 4-stroke automotive detergent oil.

SAE 10W-30 is recommended for general use. Other viscosities shown in the chart may be used when the average temperature in your area is within the recommended range.

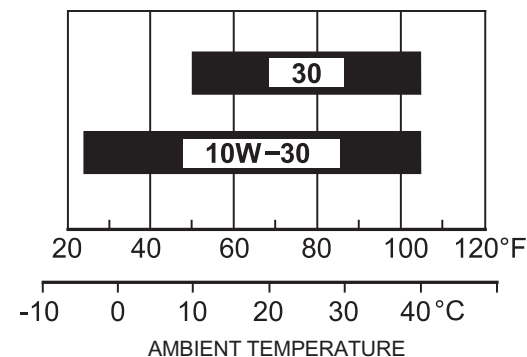

### TRANSMISSION OIL RECOMMENDATIONS

The tiller is shipped WITHOUT TRANSMISSION OIL. Fill in oil before use.

- Remove the transmission oil filler cap.
- Recommended oil is 80W-90  
Recommended capacity is 500ml -600ml.
- Screw in the oil filler cap.



### AIR FILTER INSPECTION

1. Unscrew the wing nut, and remove the air filter cover. Check the foam element to be sure they are clean and in good condition.
2. If the foam element are dirty, clean them as described below. Replace the foam element if they are damaged.
3. Reinstall the air filter cover, and tighten the wing nut securely.



AIR FILTER COVER



FOAM ELEMENT

#### NOTICE

*Operating the engine without an air filter, or with a damaged air filter will allow dirt to enter the engine, causing rapid engine wear.*

### AIR FILTER CLEANING

A dirty air filter will restrict air flow to the carburetor, reducing engine performance. If you operate the tiller in very dusty areas, clean the air filter more frequently than specified in the *Maintenance Schedule*.

1. Remove the wing nut and air filter cover.
2. Remove the foam element and separate them.
3. Carefully check the foam element for holes or tears and replace if necessary.
4. Clean the foam element if they are to be reused.

**Foam element:** Clean in warm soapy water, rinse and allow to dry thoroughly, or clean with a high flash point solvent and allow to dry.

5. Dip the element in clean engine oil and squeeze out all the excess oil.

Excess oil will restrict air flow through the foam element and may cause the exhaust to smoke when the engine starts.

6. Wipe dirt from the inside of the air filter cover using a moist rag.
7. Reinstall the foam element and grommet. Install the air filter cover, and tighten the wing nut.

### CLUTCH CABLE ADJUSTMENT

If drive belt is loosen or the tiller don't go when throttle lever is 2/3 engaged, Clutch cable should be adjusted. Loosen the locking nut and turn the adjusting nut in or out just enough to eliminate free play. Do not overtighten.

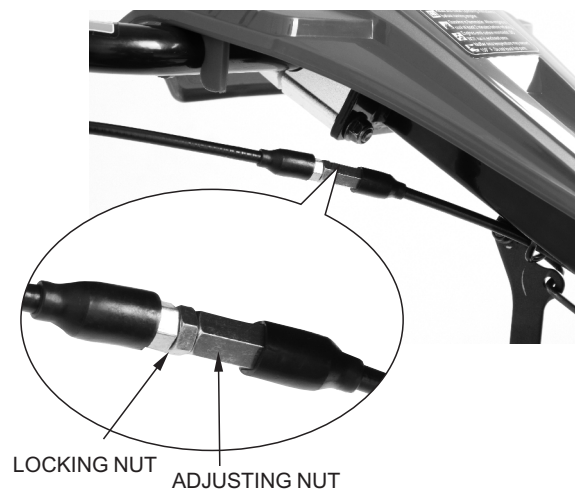

### REVERSE CABLE ADJUSTMENT

If drive belt is loosen or the tiller don't go when reverse lever is 2/3 engaged, Reverse cable should be adjusted. Same way as CLUCH CABLE ADJUSTMENT when adjusting reverse cable.

### SPARK PLUG SERVICE

#### NOTICE

*An incorrect spark plug can cause engine damage.*

1. Disconnect the spark plug cap, and remove any dirt from around the spark plug area.

## SERVICING YOUR TILLER

2. Remove the spark plug with a 13/16-inch spark plug wrench.

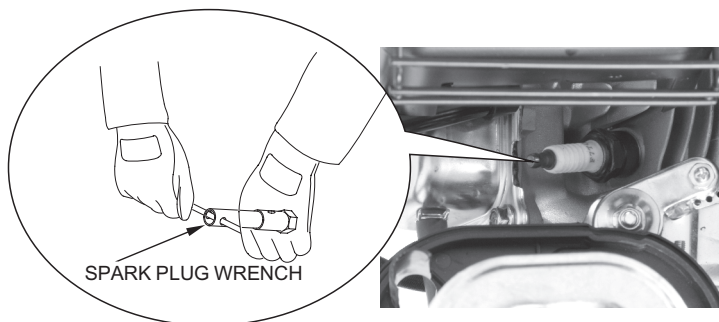

3. Inspect the spark plug. Replace it if the electrodes are worn, or if the insulator is cracked or chipped.

4. Measure the spark plug electrode gap with a wire-type feeler gauge. Correct the gap, if necessary, by carefully bending the side electrode.

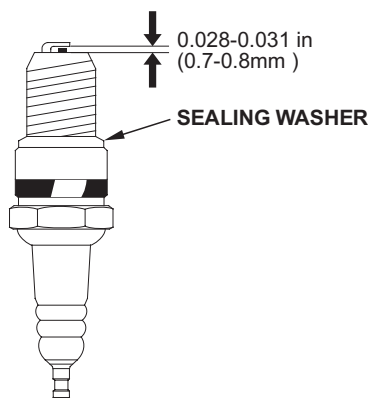

The gap should be:  
0.028—0.031 in(0.7—0.8mm)

5. Install the spark plug carefully, by hand, to avoid cross-threading.
6. After the spark plug seats, tighten with a 13/16-inch spark plug wrench to compress the washer. If reinstalling a used spark plug, tighten 1/8-1/4 turn after the spark plug seats.

If installing a new spark plug, tighten 1/2 turn after the spark plug seats.

### NOTICE

*A loose spark plug can overheat and damage the engine. Overtightening the spark plug can damage the threads in the cylinder head.*

7. Attach the spark plug cap.

## SERVICING YOUR TILLER

### DRIVE BELT CHANGE

1. Stop the engine, and remove the spark plug cap.

2. Unscrew the plastic cover by loosening cross screws both sides and hex screw on the top.

3. Remove the transmission oil filler cap.

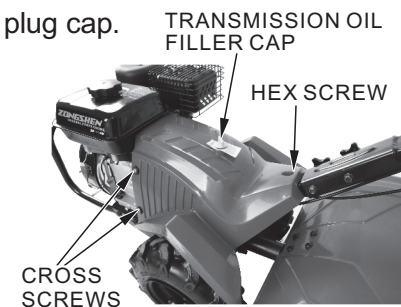

4. Unscrew the engine bolts and nuts both sides.

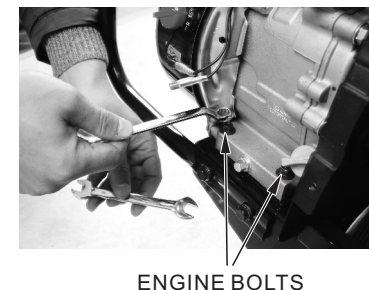

5. Release the clutch cable and take out clutch cable head.



6. Take out the reverse cable.

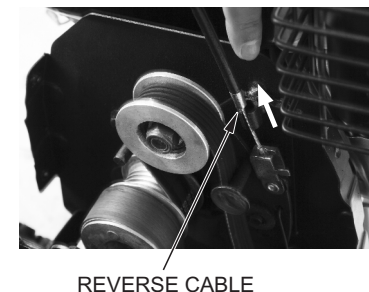

## DRIVE BELT CHANGE

7. Release the spring for reverse cable, and take out the engine.



REVERSE SPRING

8. Take out the forward belt and reverse belt from their own pulley.

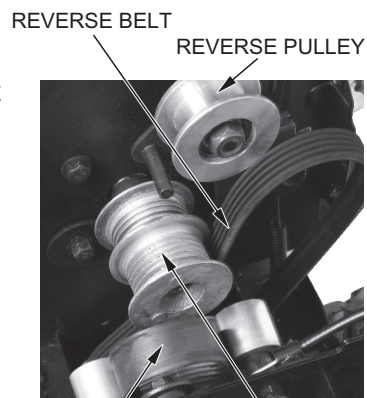

FORWARD BELT

9. Unscrew the belt protection cover underside.



BELT PROTECTION COVER

## DRIVE BELT CHANGE

10. Take out the belt protection cover.

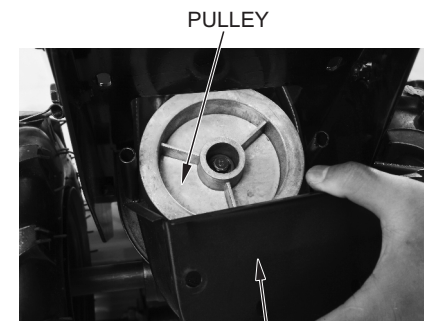

BELT PROTECTION COVER

11. Push off the belt holder slightly and take out the belt needed to be changed.

Install new belts as original way. Install back the belt protection cover.

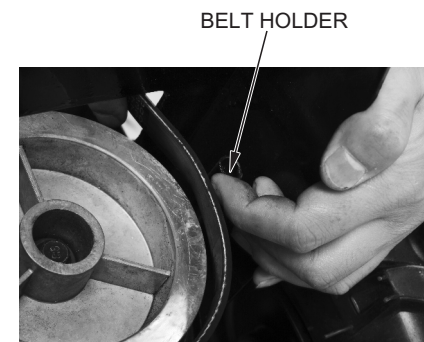

12. Install back the engine, put the new belts on their own way.

Adjust the space between pulley and housing at 28.5mm.

After adjustment, tighten the engine screws securely. Then put the plastic cover back and tighten securely.

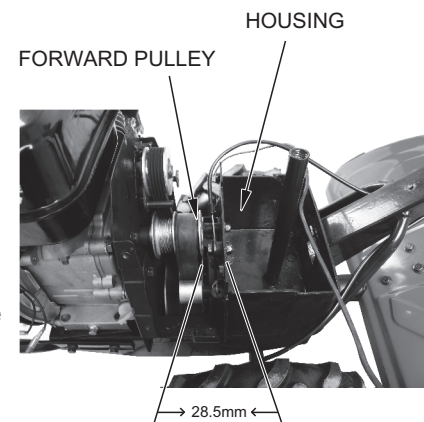

## TINE REPLACEMENT

1. Inspect the tines. Replace them if the tines are worn out.
2. Take out the locking pin from the clevis pin.
3. Take out the tines sets.
4. Unscrew the bolts and nuts.
5. Change the worn tines. Notice the direction of the tines.
6. Install back the tines sets by tightening the bolts and nuts. Notice the different direction of installment way for bolts and nuts.
7. Lock the sets by clevis pin and locking pin.

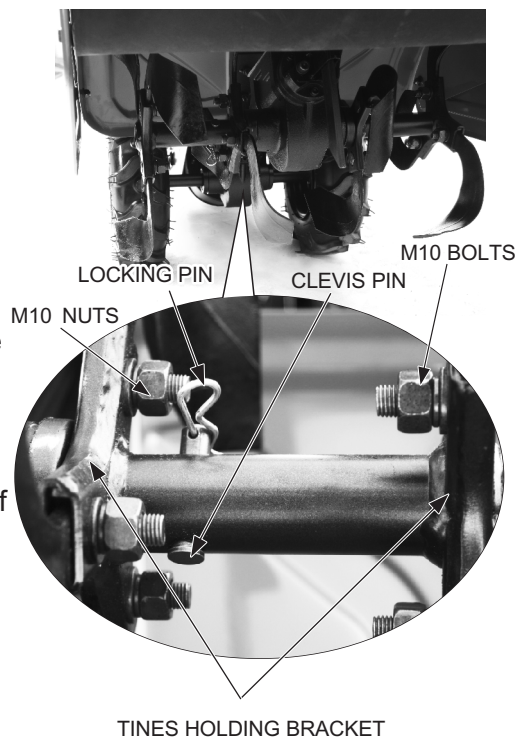

## SPARK ARRESTER SERVICE (optional equipment)

Your engine is not factory-equipped with a spark arrester. In some areas, it is illegal to operate an engine without a spark arrester. Check local laws and regulations.

## TIRE PRESSURE CHECK

Check the tire pressure. Improper inflation can reduce both tire life and load carrying capacity.

Make sure the clevis pin is securely installed.

Tire size: 3.50-6"

Tire pressure: 17.1 psi (1 20 kPa , 1.2 kgf/cm<sup>2</sup>)

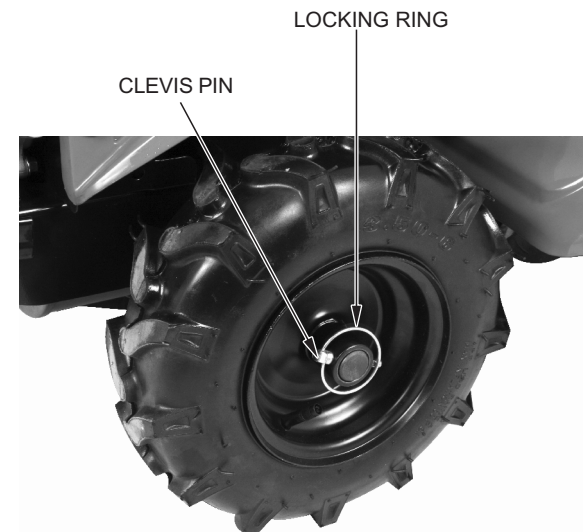

## STORAGE PREPARATION

Proper storage preparation is essential for keeping your tiller trouble-free and looking good. The following steps will help to keep rust and corrosion from impairing your tiller's function and appearance, and will make the engine easier to start when you use the tiller again.

### Cleaning

1. Wash the tiller, including the underside.

#### Engine

Wash the engine by hand, and be careful to prevent water from entering the air cleaner.

#### NOTICE

- *Using a garden hose or pressure washing equipment can force water into the air filter. Water in the air filter will soak the foam element and can enter the carburetor or engine cylinder, causing damage.*
- *Water contacting a hot engine can cause damage. If the engine has been running, allow it to cool for at least half an hour before washing.*

#### Tiller

If using a garden hose or pressure washing equipment to clean the tiller, be careful to avoid getting water on the belts.

#### NOTICE

*Spraying water on hot tine shaft bearings can cause them to be damaged from cooling too quickly.*

2. After washing the tiller, wipe dry all accessible surfaces.
3. Start the engine outdoors, and let it run until it reaches normal operating temperature to evaporate any water remaining on the engine.
4. While the engine is running, operate the clutch lever to expel water from the pulleys, belts, and other moving items.
5. Stop the engine and allow it to cool.
6. After the tiller is clean and dry, touch up any damaged paint and coat other areas with a light film oil. Lubricate the clutch cable core and reverse cable core with a silicone spray lubricant.

### Fuel

#### NOTICE

*Depending on the region where you operate your equipment, fuel formulations may deteriorate and oxidize rapidly. Fuel deterioration and oxidation can occur in as little as 30 days and may cause damage to the carburetor and/or fuel system. Please check with your servicing dealer for local storage recommendations.*

Gasoline will oxidize and deteriorate in storage. Old gasoline will cause hard starting, and it leaves gum deposits that clog the fuel system. If the gasoline in your tiller deteriorates during storage, you may need to have the carburetor and other fuel system components serviced or replaced.

The length of time that gasoline can be left in your fuel tank and carburetor without causing functional problems will vary with such factors as gasoline blend, your storage temperatures, and whether the fuel tank is partially or completely filled. The air in a partially filled fuel tank promotes fuel deterioration. Very warm storage temperatures accelerate fuel deterioration. Fuel deterioration problems may occur within a few months, or even less if the gasoline was not fresh when you filled the fuel tank.

You can extend fuel storage life by adding a gasoline stabilizer that is formulated for that purpose, or you can avoid fuel deterioration problems by draining the fuel tank and carburetor.

### ***Adding a Gasoline Stabilizer to Extend Fuel Storage Life***

When adding a gasoline stabilizer, fill the fuel tank with fresh gasoline. If only partially filled, air in the tank will promote fuel deterioration during storage. If you keep a container of gasoline for refueling, be sure that it contains only fresh gasoline.

1. Add gasoline stabilizer following manufacturer's instructions.
2. After adding a gasoline stabilizer, run the engine outdoors for 10 minutes to be sure that treated gasoline has replaced the untreated gasoline in the carburetor.
3. Stop the engine, and turn the fuel valve to the off position.

### ***Draining the Fuel Tank and Carburetor***

1. Place an approved gasoline container below the carburetor, and use a funnel to avoid spilling fuel.
2. Loosen the carburetor drain screw, and then move the fuel valve to the ON position.

### **⚠ WARNING**

Gasoline is highly flammable and explosive.

You can be burned or seriously injured.

Never use gasoline to clean engine parts. Use a nonflammable solvent.

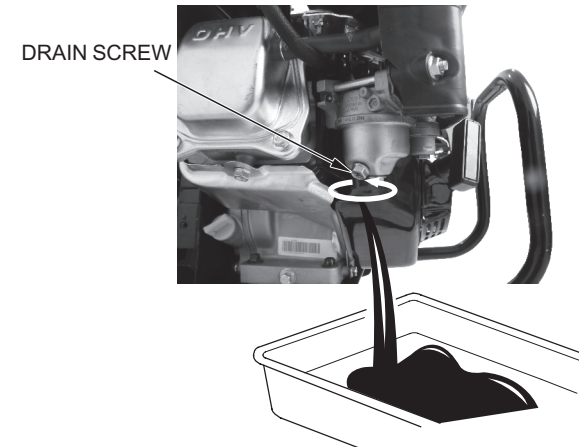

3. After all the fuel has drained into the container, tighten the drain screw securely.
4. Remove and empty the sediment cup, and then reinstall the sediment cup and tighten securely.

## STORAGE

### STORAGE PRECAUTIONS

If your tiller will be stored with gasoline in the fuel tank and carburetor, it is important to reduce the hazard of gasoline vapor ignition. Select a well-ventilated storage area away from any appliance that operates with a flame, such as a furnace, water heater, or clothes dryer. Also avoid any area with a spark-producing electric motor or where power tools are operated.

If possible, avoid storage areas with high humidity because that promotes rust and corrosion.

Unless all fuel has been drained from the fuel tank, leave the fuel valve in the OFF position to reduce the possibility of fuel leakage.

Place the tiller on a level surface. Tilting can cause fuel or oil leakage.

When the engine and exhaust system is cool, cover the tiller to keep out dust. A hot engine and exhaust system can ignite or melt some materials. Do not use sheet plastic as a dust cover. A nonporous cover will trap moisture around the tiller, promoting rust and corrosion.

## TAKING CARE OF UNEXPECTED PROBLEMS

PROBLEM	POSSIBLE CAUSE	CORRECTION
Will Not Start or Hard to Start	1. Out of Fuel	1. Fill Fuel Tank
	2. Throttle control not set properly	2. Place throttle control 1/3 away from SLOW
	3. Engine flooded	3. Wait Several minutes before starting again
	4. Dirty air filter	4. Clean or replace air filter
	5. Water in fuel	5. Drain fuel tank and carburetor, fill with fresh fuel
	6. Clogged fuel tank, line	6. Remove fuel tank or filter and clean
	7. Loose spark plug wire	7. Make sure plug wire is seated properly on plug
	8. Stale or dirty fuel	8. Drain fuel tank and carburetor, fill with fresh fuel
	9. Bad spark plug or improper gap	9. Replace spark plug or adjust gap.
	10. Carburetor out of adjustment	10. Make necessary adjustments
Loss of Power	1. Engine is overloaded	1. Set depth stake or wheels for shallow tilling
	2. Dirty air filter	2. Clean or replace air filter
	3. Bad spark plug or improper gap	3. Replace spark plug or adjust gap
	4. Stale or dirty fuel	4. Drain fuel tank and carburetor, fill with fresh fuel
	5. Water in fuel	5. Drain fuel tank and carburetor, fill with fresh fuel
	6. Clogged fuel tank, line	6. Remove fuel tank or filter and clean
	7. Loose spark plug wire	7. Make sure plug wire is seated properly on plug
	8. Dirty or clogged muffler	8. Clean or replace muffler
	9. Carburetor out of adjustment	9. Make necessary adjustments
	10. Poor compression	10. Contact an authorized service center
Engine Overheats	1. Dirty air filter	1. Clean or replace air filter
	2. Dirty engine	2. Clean cylinder fins, air filter, muffler
	3. Partially plugged muffler	3. Remove and clean muffler
	4. Improper carburetor adjustment	4. Adjust carburetor
Tilling Problems	1. Engine speed is too slow for soil conditions	1. Move the throttle to the FAST position
	2. Tiller is moving too fast for soil conditions	2. Reduce throttle speed
	3. Drag bar adjustment set too high	3. Lower drag bar adjustment
	4. Tines dull, worn, or damaged	4. Replace tines if necessary
	5. Wrong tines installed	5. Install correct tines
	6. Tines installed incorrectly	6. Install tines correctly

# 221 **BBH**460**4T**

GASOLINE TILLER (4-STROKE)

---

Kraissmann Stromerzeugung Maschinen GmbH,  
Nordrhein-Westfalen, Düsseldorf  
Deutschland